

TAKAMAZ
GENERAL CATALOG

ENGLISH

De Sign

EASY WAYS
TO REDUCE WASTE

NO! CO₂

NO MORE
OVERTIME



TAKAMAZ

Aiming for Carbon-neutral Production

The new TAKAMAZ plant (Asahi plant) is contributing to global environmental conservation by introducing energy-saving equipment including air conditioning systems that utilize solar power generation* and well water. ※Scheduled to be installed sequentially from 2023

Environmental Technology Supporting Customers' Push Toward Carbon Neutrality

- **Increased energy conservation**
(adoption of regenerative energy, high-efficiency motors)
- **More compact, increased space savings**
Successful integration of loading units, oil mist collectors, chip conveyors, coolant temperature regulators, etc.
- **Defectives reduced by stable precision machining**
- **Cycle times shortened by speed increases**
- **Improved operability and maintainability**
- **Reduced number of structural components**



Lineup Realizing Process Integration and Productivity Improvements

Turning + grinding



SKV-8

Skiving machining

Compound machining



XYseries

Compound machining

Turning + hobbing



XT-8MY

Compound machining

Ultrasonic vibration cutting

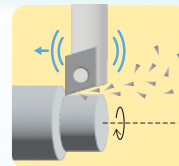

Chip breaking machining method

Operating system

T-Support System[®]

TAKAMAZ OS

F Loader System

Thermony[®] **Spimony**[®]

EASY WAYS
TO REDUCE WASTE

NO! CO₂

NO MORE
OVERTIME



TAKAMAZ LINE UP

X series PAGE
03

1 spindle 1 turret

Our total production count is a proof of reliability. This is a TAKAMAZ standard that has evolved for single lathes.

XW series PAGE
05

2 spindle 2 slide

Simultaneous machining of both or the same sides of the parts for total complete process machining. The functions of two units within the space of a single unit.

XY series PAGE
07

Multi-turning

With 2 spindle and 2 turret, there are lots of possible cutting methods. Complex parts can be processed at shorter amount of time.

GANG TYPE series PAGE
07

1 spindle 1 slide

Gang type precision lathe that has honed the essentials.

GSL series PAGE
08

1 spindle 1 turret

A simple machine best in its class among manual operated machines, focusing the cost performance.

SKIVING MACHINE PAGE
08

1 spindle 1 turret

Introducing a Special Machine Specifically Designed for Skiving.

OPTION SYSTEM PAGE
09

LOADER SYSTEM PAGE
10

AUTOMATION SYSTEM PAGE
11

ADVANCED TECHNOLOGY PAGE
12

OPERATING SYSTEM PAGE
13

A New System at a New Plant

We will make products tailored to individual customers' needs based on a lineup that, in addition to productivity, considers everything from production efficiency and production space to the environment, durability and future-proofing.



“Starting Point of TAKAMAZ”
Integration of the Power of Technology.

X series



1-spindle 1-turret

Our total production count is proof of reliability. This is a TAKAMAZ standard that has evolved for single lathes.



Standard of Single Lathes

Ideal for small part processing

XTS-6

6 inch Chuck



Received the silver award in the product category at the Ishikawa Ecodesign Awards 2024



XT-6 XT-6M

6(8) inch Chuck



XT-8 XT-8M

8(10) inch Chuck



Equipped with power tools and a Y axis

XT-8MY

8(10) inch Chuck

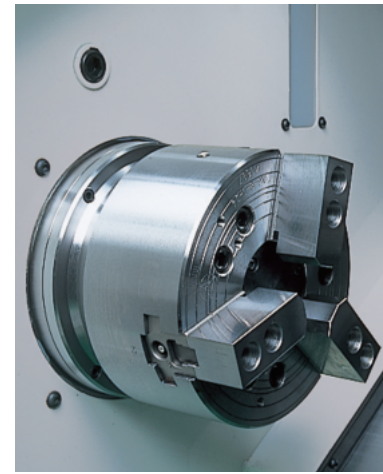

Xseries Machine Specifications

Item	Unit	XTS-6	XT-6 Standard	XT-6M Power tool type	XT-8 Standard	XT-8M Power tool type	XT-8MY	XTL-8 8-station Specifications(Standard) 12-station Specifications(Optional)
Chuck size	inch	Collet,6	Collet,6(8)		Collet,8(10)		Collet,8	Collet,8(10)
Spindle bearing I.D.	mm	φ75	φ75(φ85)		φ100(φ120)		φ100	φ100(φ120)
Spindle speed	min ⁻¹	Max.5,000	Max.4,500(6,000)(3,500)		Max.3,500(5,000)(3,000)		Max.4,000	Max.4,000(5,000)(3,000)
Tool post type		8-station turret	8-station(12-station)turret	12-station turret	8-station(12-station)turret	12-station turret	12-station turret	8-station turret 12-station turret
Max. stroke	mm	X:120 Z:230	X:120 Z:280		X:190 Z:400	X:190 Z:420	X:175 Z:420 Y:+35,-40	X:190 Z:600
Rapid traverse	m/min	X:18 Z:24	X:18 Z:24		X:18 Z:24	X:18 Z:24	X:18 Z:24 Y:10	X:18 Z:24
Spindle motor	kW	AC7.5/5.5	AC7.5/5.5(AC11/7.5)		AC11/7.5:φ100 3,500min ⁻¹ AC15/11:φ100 5,000min ⁻¹ AC15/11:φ120 3,000min ⁻¹		AC15/11	AC15/11
Power tool capability	Milling	mm	—	φ10	—	φ20	φ16	—
	Tap	mm	—	M6	—	M16	M16	—
Dimensions (L×W)	mm	1,105 × 1,380	1,360 × 1,370		1,600 × 1,535	1,750 × 1,535	1,780 × 1,685	1,840 × 1,930
Controller		TAKAMAZ & FANUC Oi-TF Plus	TAKAMAZ & FANUC Oi-TF		TAKAMAZ & FANUC Oi-TF Plus		TAKAMAZ & FANUC Oi-TF Plus	TAKAMAZ & FANUC Oi-TF Plus

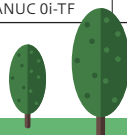

Can handle long shaft work up to 598 mm

XTL-8

 8(10) inch Chuck



NEW



Equipped with power tools and a Y axis

XTL-8MY

 8 inch Chuck



NEW



Equipped with power tools, a Y axis and a sub-spindle

XTL-8MYS

 8 inch Chuck



NEW





Capable of compound machining

XTT-500 XTT-500M

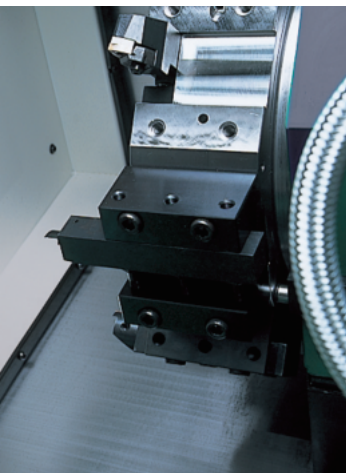
 8(10) inch Chuck



XTL-8MY 	XTL-8MYS 		XTT-500 Standard	XTT-500M Power tool type
	Main-spindle	Sub-spindle		
Collet,8	Collet,8	Collet,6	Collet,8(10)	Collet,8
φ100	φ100	φ75	φ100(φ120)	φ100
Max.4,000	Max.4,000		Max.4,000(3,500)	Max.4,000
12-station turret	12-station turret		8-station turret × 2	
X:175 Z:550 Y:+35, -40	X:175 Z:550 Y:+35, -40 A:400		X:105 Z:450	
X:18 Z:24 Y:10	X:18 Z:24 Y:10 A:30		X:18 Z:24	
AC15/11	AC15/11	AC7.5/5.5	AC15/11(18.5/15)	AC15/11
φ20	φ20		—	φ10
M16	M16		—	M4 ~ M8
1,840 × 1,930	2,764(1,840*) × 1,965		1,695 × 1,830	
TAKAMAZ & FANUC Oi-TF Plus	TAKAMAZ & FANUC Oi-TF Plus		TAKAMAZ & FANUC Oi-TF	

*: Bed width () :Options.

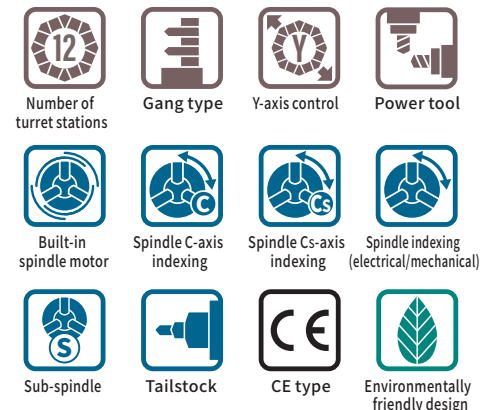

From High Volume Machining to Heavy Cutting.
Revolutionary Machine with 2-Spindle and 2-Slide

XW series



2-spindle 2-slide

Simultaneous machining of both or the same sides of the parts for total complete process machining. The functions of two units within the space of a single unit.



Ideal for Small Part Processing

XWG-3

3 inch / 4 inch Chuck



Received a Japan Institute of Design Award at the 54th Machinery Industrial Design Awards (IDEA) (Nikkan Kogyo Shimbun)



Integrating Various Process

XW-60 XW-60M

6 inch Chuck



Fastest Loading Cycle in its Class

XW-130M

8 inch Chuck

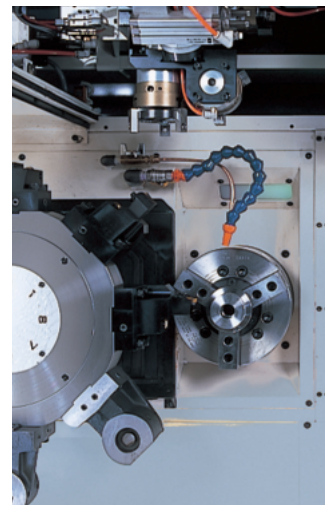

XWseries Machine Specifications

Item	Unit	XWG-3	XW-60 Standard	XW-60M Power tool type
Chuck size	inch	Collet, 3,4	Collet, 6(5) × 2	
Spindle bearing I.D.	mm	φ60	φ75 (φ65)	
Spindle speed	min ⁻¹	Max. 8,000 (6,000*1)	Max. 4,500 (6,000)	
Tool post type		Gang type (Max. 4 pcs.)	8-station turret × 2	10-station turret × 2
Max. stroke	mm	X:160 Z:230	X:125 Z:140	
Rapid traverse	m/min	X:16 Z:20	X:21 Z:18	
Spindle motor	kW	AC5.5/3.7	AC 7.5/5.5 × 2	
Power tool capability	Milling	—	—	φ13
	Tap	—	—	M4~M10
Dimensions (L×W)	mm	1,340 × 2,130	1,595 (1,950) × 2,005	1,695 (1,950) × 2,005
Controller		TAKAMAZ & MITSUBISHI M830VV	TAKAMAZ & FANUC 0i-TF	



Supporting center can be mounted

XWT-8

8inch Chuck



Received a JSPE (Japan Society for Precision Engineering) Monozukuri Award

NEW

Large Flange-Like Workpiece

XW-200

10inch Chuck

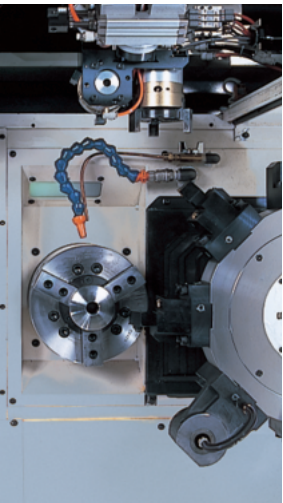

Large Flange-Like Workpiece

XWT-10

10inch Chuck



XW-130M Power tool type	XWT-8 NEW	XW-200	XWT-10
Collet, 8 × 2	Collet, 8	Collet, 10 × 2	Collet, 10 × 2
φ100	φ100	φ120	φ120
Max. 4,000	Max. 4,000	Max. 2,800	Max. 2,800 (4,000)
10-station turret × 2	8-station turret	8-station turret × 2	10-station turret × 2
X:170 Z:220	X:150 Z:180	X:170 Z:220	X:170 Z:270
X:24 Z:24	X:24 Z:24	X:24 Z:24	X:24 Z:24
AC11/7.5 × 2	AC 11/7.5	AC18.5/15 × 2	AC18.5/15 × 2
φ16	—	—	—
M4~M10	—	—	—
1,990 (2,350 ^{※2}) × 2,330	1,890 (Overall width : 2,250) × 2,187	1,990 (2,350 ^{※2}) × 2,330	2,030 (2,350 ^{※2}) × 2,370
TAKAMAZ & FANUC Oi-TD (Oi-TF ^{※3})	FANUC Oi-TF Plus	TAKAMAZ & FANUC Oi-TF	TAKAMAZ & FANUC Oi-TF

※1. Hydraulic specification ※2. Machine width with loader spec. ※3. Optional with power tools. () : Options.



TAKAMAZ Compact Machines
Suitable for Compound Machining

XY series



Multi-Turning

Gang Type Precision Lathe
That Has Honed the Essentials.

GANG TYPE series



1-spindle 1-slide



XG-4



XV-3

With 2 spindle and 2 turret, there are lots of possible cutting methods.
Complex parts can be processed at shorter amount of time.



Sub-Spindle + Power Tools

XYT-51

6inch Chuck



High-Accuracy Turning with Built-In Motors

XG-4

4inch Chuck



Fastest Loading Cycle in its Class

J-WAVE PLUS

4inch Chuck



Integration of Diverse Processes

XV-3

3inch / 4inch Chuck



Won the Judges' Special Award at the 52nd Machinery Industrial Design Awards (IDEA)

XYseries Machine Specifications

Item	Unit	XYT-51			
		φ51 THRU,BMT45 specification		φ65 THRU,BMT55 specification(OP)	
Chuck size	inch	Main-spindle	Sub-spindle	Main-spindle	Sub-spindle
		Collet,6		Collet,8	
Spindle bearing I.D.	mm	φ100	φ85	φ120	φ100
Spindle speed	min ⁻¹	Max.5,000		Max.4,000	
Tool post type		12-station turret,24ST,BMT45		12-station turret,24ST,BMT55	
Max. stroke	mm	X1:162.5 Z1:500 Y:+35 X2:170 Z2:500 A:550		X1:162.5 Z1:500 Y:+40-35 X2:170 Z2:500 A:550	
Rapid traverse	m/min	X:18 Z:30 Y:12 A:30		X:18 Z:30 Y:12 A:30	
Spindle motor	kW	AC18.5/15/11	AC9/7.5/5.5	AC18.5/15/11	AC9/7.5/5.5
Power tool Milling	mm	φ13		φ20	
capability Tap	mm	M12		M16	
Dimensions (L×W)	mm	2,988 × 2,163		3,000 × 2,163	
Controller		TAKAMAZ & FANUC 32i-B			

() :Options.

GANGTYPE series Machine Specifications

Item	Unit	XG-4		J-WAVE PLUS	XV-3
		Main-spindle	Sub-spindle		
Chuck size	inch	Collet,4		Collet,4	Collet,3,4
Spindle bearing I.D.	mm	φ65		φ65	φ60
Spindle speed	min ⁻¹	Max.8,000		Max.4,500	Max.10,000
Tool post type		Gang type		Gang type	Gang type
Max. stroke	mm	X:200	Z:250		X:160 Z:200 Y:265
Rapid traverse	m/min	X:18	Z:18		X:12 Z:24 Y:24
Spindle motor	kW	AC7.5/5.5/3.7		AC5.5/3.7	AC5.5/3.7
Dimensions (L×W)	mm	1,506 × 1,250 (780 × 1,735*)			1,600 (2,075) × 2,130 × 2,230
Controller		TAKAMAZ & MITSUBISHI M80			TAKAMAZ & MITSUBISHI M80

*When the loader is mounted.

() :Options.

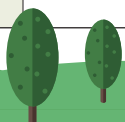

A Simple Machine Best in Its Class among Manual Operated Machines, Focusing the Cost Performance.

Global Strategy Lathe

GSL series



1-spindle 1-turret

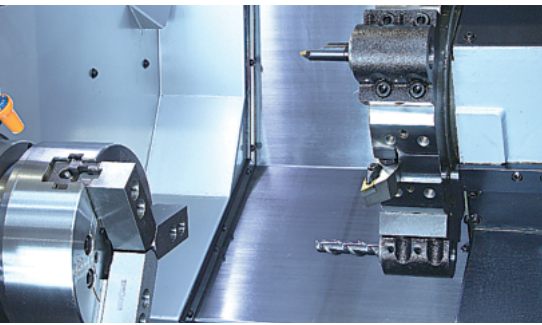

Excellent Cost Performance



GSL-15 PLUS

8 inch Chuck



SKIVING MACHINE



1-spindle 1-turret

A Machine Specialized for Skiving Turning + Grinding on This One Machine



SKV-8

8 inch Chuck



Limited exclusively to domestic sales in Japan

GSLseries Machine Specifications

Item	Unit	GSL-15 PLUS
Chuck size	inch	Collet,8
Spindle bearing I.D.	mm	φ100
Spindle speed	min ⁻¹	Max.3,500
Tool post type		8-station turret
Max. stroke	mm	X:175 Z:330
Rapid traverse	m/min	X:18 Z:24
Spindle motor	kW	AC7.5/5.5
Dimensions (L×W)	mm	1,875 (With tailstock : 1,990) × 1,680
Controller		TAKAMAZ & FANUC 0i-TF

SKV-8 Machine Specifications

Item	Unit	SKV-8
Chuck size	inch	Collet,8
Spindle bearing I.D.	mm	φ100
Spindle speed	min ⁻¹	Max.5,000
Tool post type		12-station turret
Max. stroke	mm	X:150 Z:400 Y:±35
Rapid traverse	m/min	X:18 Z:24 Y:12
Spindle motor	kW	AC 15/11
Dimensions (L×W)	mm	2,270 × 1,690
Controller		TAKAMAZ & FANUC 0i-TF



Customizable for unique specifications

OPTION SYSTEM

By applying our experiences in manufacturing of peripheral devices and our wealth of design achievements, we will continue to meet the needs of our customers.

A production line with different varieties of peripheral devices and loading variations can be designed.

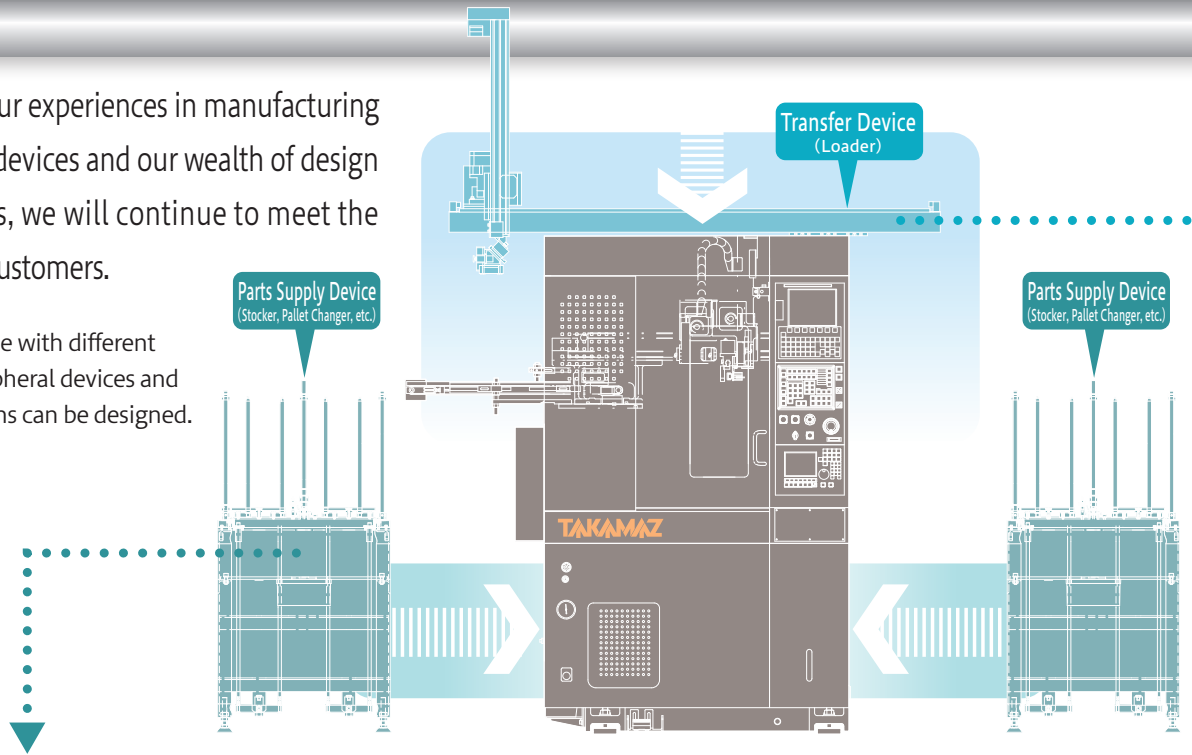

Automation Peripheral Devices

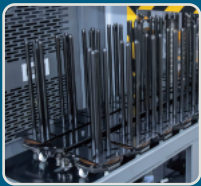

■ **Station Stocker**
Flexible Multi-layer stocker to accommodate different part diameter sizes.



■ **Flat Stocker**



■ **Stocker for Shaft Type Parts**



■ **Parts Feeder**
Workpieces can be stored together with the tray.

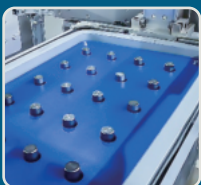

■ **Tray Changer**
Workpieces can be stored in individual trays.

Quality/Environment Control Unit

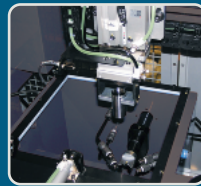

■ **Cleaning Unit**
Without operator intervention, cleaning is performed automatically.



■ **Measuring Devices**
Feeds dimensional errors back to the machine to maintain high-quality dimensional accuracy.



■ **Oil Mist Collector**
Oil mist collection facilitates a clean production environment.



■ **Automatic Fire Extinguisher**
If fire breaks out in the machine during automatic operations, fire extinguishing agent is automatically discharged.

Cutting Efficiency/Chip Disposal

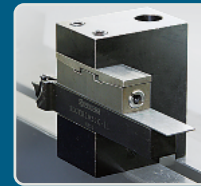

■ **Alloyed Clamp Holder for Vibration Suppression**
Inhibiting the progression of wear boundary is expected to extend cutting tool life in high speed machining.



■ **Chip Conveyor (Spiral Type)**
Mounted on the rear side. Chip disposal is done semi-automatically in minimal space.



■ **(Floor Type)**
Mounted on the rear side. Chips are reliably discharged outside the machine.



■ **High-Pressure Coolant**
Constantly cooled coolant is discharged at high pressure so that the tool life is significantly prolonged.



■ **Semi-Dry Machining**
Ultracoolant, highly-lubricating organic coolant is applied to the correct point on the cutting edge, realizing semi-dry machining.

LOADER SYSTEM

Encouraged from sales of more than 65 years, with "Integral loader" design philosophy in mind, TAKAMAZ will lead the consistent support service follow up and support system built on trust, leading to increased productivity.

Compact Loader

- Hi Speed Loader mounted on the machine to save space.
- A dedicated servo controller allows speedy setup.

Gantry Loader

- Gantry-type servo loader with high rigidity.
- The traverse distance can be extended, ensuring extremely flexible line configuration and systemization of peripheral equipment.

Space Saving Accessory Devices
 Improving Durability
 Pursuing of the Low Cost
 Short Loading Time
 Flexible System Line Configuration
 Improving Operability

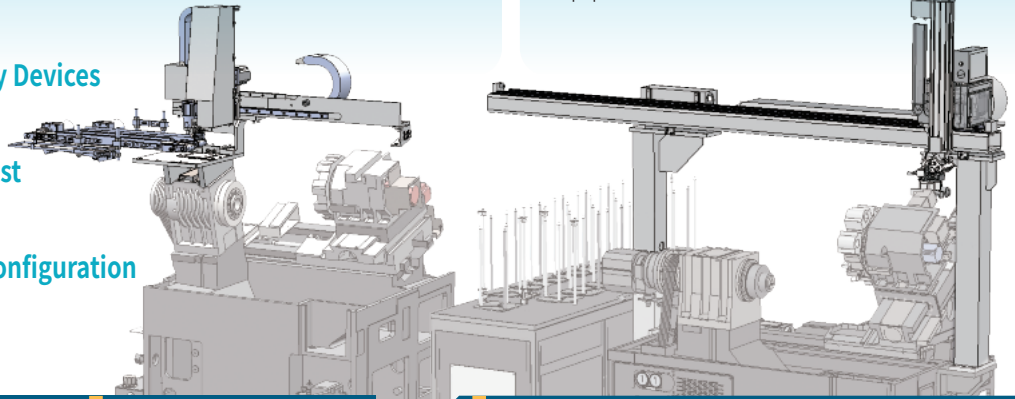

For Small and Short Workpiece

For Flange Workpiece

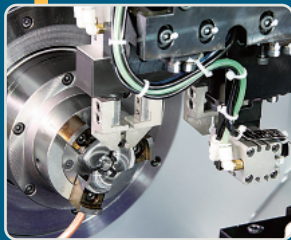

Parallel Hand



L Hand

For Front and Back Cutting Workpiece

For Shaft Workpiece



Σi GTH Hand



Pendulum Hand

Workpiece Delivery from Transport Unit Using a Conveyor

Vertically-Oriented Workpiece
 (For Machining the Bottom Face)



E Turn Device

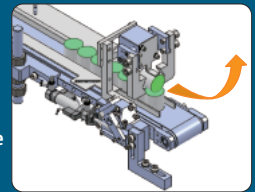

Standing Workpiece
 (For Cutting the Top Surface)

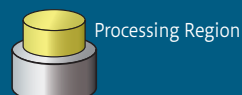

Y Turn Device

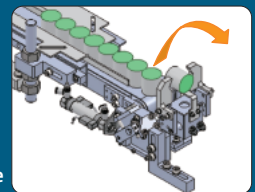

Horizontally Placed
 Small Diameter Workpiece



Pickup Device

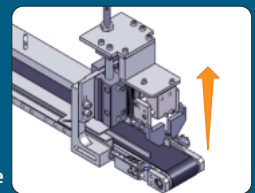

TAKAMAZ Collet Chuck



The collet chuck developed and marketed under the TAKAMAZ brand is manufactured in the factory where an integrated system is used to streamline every part of the production, from machining to heat treatment. Collet run-off accuracy conforms to TAKAMAZ standard, which is even higher than Japanese Industrial Standards (JIS), allowing us to provide our customers with exceptionally dependable products.



ServoROT® series

A Highly-Productive Robot System That Solves Your Problems!

This is a workpiece loading/unloading automation system that delivers the “simple operability” and “reduced setup time” required to deal with the issues posed by multiproduct, variable quantity production and the shortage of labor.

With the robot and material supply section developed as packages, the TAKAMAZ **ServoROT® series** doesn't just improve productivity but also greatly helps to reduce the burden on the operator.



ServoROT-X1



Use of the FANUC CRX series collaborative robot, which does not require a safety fence, allows configuration of a safe and reliable supply system. In addition, the collet chuck can be changed.

*Max. weight capacity: 20 kg

*12-inch operation panel adopted



ServoROT-01

A multi-layer tray is integrated as a supply device, allowing prolonged unmanned operation.



ServoROT-00

A flat-type workpiece stocker is used to address flexible needs. The robot base is angled so as not to obstruct the space required for setup at the lathe.

■ Reduces Personnel Costs

This system loads/unloads workpieces with a robot that is integrated with a tray changer. It realizes unmanned operation day and night, and improves production efficiency by maintaining machining quality, ensuring stable loading, and allowing multi-machine control.

■ Wide Range of Variations

Based on this robot + tray changer system, we can meet various needs including washing units and gauging systems.

■ Simple Setup

With the integrated robot + tray changer construction, setup can be completed just by teaching on site.

■ Retrofitting Even to Previous Models

The system can be retrofitted to an existing machine provided there is a space of 1.8 x 0.9 meters in front of it. Consultations are welcome.

T-ECO Support

Environmental Considerations as Standard Specifications

Spindle Acceleration/Deceleration Time Fully Adjustable

The spindle acceleration/ deceleration time can be adjusted as required to switch between operation that prioritizes cutting time and operation that prioritizes energy savings.



Acceleration/Deceleration Time Adjustable as Required
Example with spindle acceleration/deceleration set at 80%:

Power consumption **-1%**

Cycle time **+1%**

* According to actual values measured by TAKAMAZ

* In lines comprising multiple machines in sequence, when there are waiting times for material loading due to differences in process cycle times, operation that prioritizes energy savings can be used effectively to achieve power savings without increasing the line cycle time.

20% Reduction in Power Consumption while Machine is Stopped

An "idle stop function" that automatically stops power supply to the hydraulic pump when the machine is stopped is now incorporated. This provides a power conservation effect when the machine is stopped, such as during machine setup work.

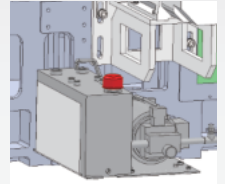

When hydraulic pump is OFF

Power consumption **-20%**

* According to actual values measured by TAKAMAZ

Power Consumption Monitor

Energy usage can be managed at all times, including the power on time, production quantity, energy consumption, average power consumption per workpiece, and energy saving effect.

This helps to reduce the environmental load and manage running costs.

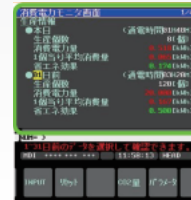

Production information (per-day basis)

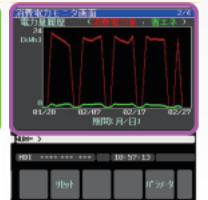

Power consumption history

T-Support System[®]

Constantly Monitors Machines and Automatically Corrects to the Appropriate Status!

Thermomy[®] Patented

Thermal Displacement Compensation System

The machined dimension values change as the machine temperature changes due to the customer's conditions of use (machining conditions) and the environmental conditions (factory temperature, etc.). This system predicts the amount of thermal displacement based on the temperature changes at each part of the machine and provides compensation values to the CNC controller. In order to minimize these changes in the machining dimension values.

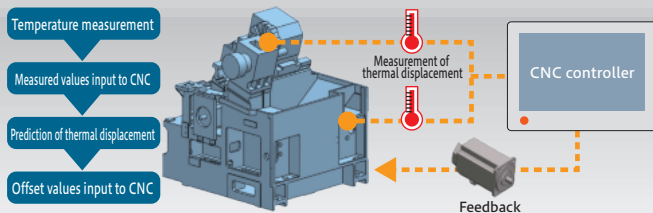

Thermomy applied - Amount of change = 6 μ m Improved by 60%

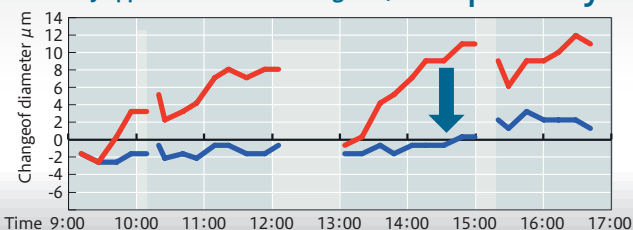

Spimomy[®] Patented

Spindle Condition Monitoring System

The application of machine fault diagnosis methods is difficult in many cases where existing threshold values are provided, because the threshold values differ for each machine. We have addressed this issue by providing a new method of diagnosis with a spindle status monitoring system based on the "characteristic space common among machines", which is determined using characteristic quantities.

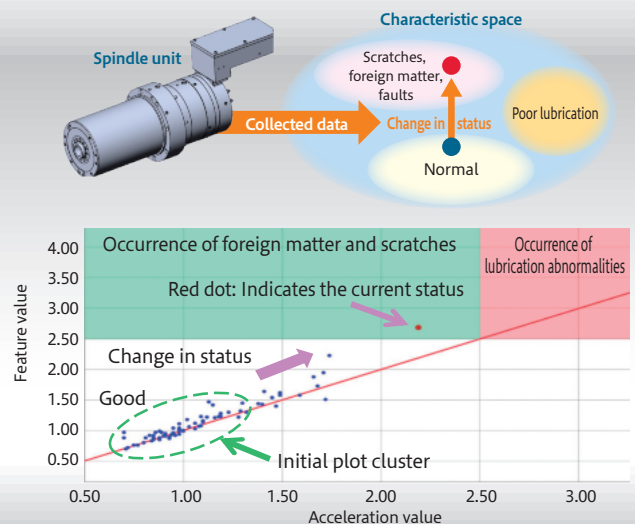

T-Program Guide

Programming Assistance Tool

The first requirement when mass producing parts using machine tools is setup. A lot of preparation is required, from understanding the shape of the material and creating a cutting program, to selecting and mounting the cutting tool and chuck. Unlike skilled workers, it takes time for inexperienced operators to master the know-how required for creating programs for cutting to the required accuracy in a short period of time, making full use of G-codes and so on. They will also be apprehensive about their ability to accomplish the cutting using the completed program without any interference. To address this, we are introducing an assistance function that enables even operators with little experience to create programs without errors, called the T-PROGRAM GUIDE.



XTS-6

Programs can be created simply by entering the necessary information in order on the screen.

1 Workpiece settings

Enter the stipulated information, such as the material and dimensions.

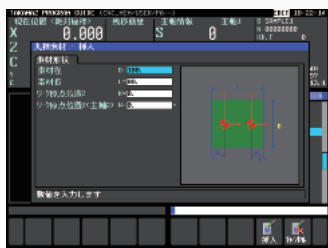

2 Tool condition settings

The cutting conditions are automatically selected according to the selected tool and workpiece material.



3 Cutting cycle settings

Cutting cycles appropriate for the tool to be used are displayed, allowing selection without faltering.



4 Simulation (MGi)

The created program can be checked through a simulated animation.

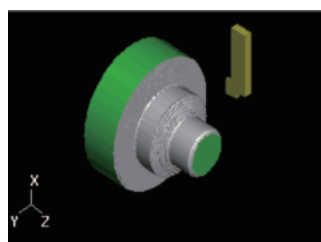

Functions allowing tool management and facilitating process editing are provided.

● Tool management

- Input of condition settings for each program is simplified by pre-registration of tool information (material, shape, T codes, etc.).
- Cutting conditions according to tool material and workpiece material are put in a database.



● Process editing

- Cycles and conditions can be checked for each process, thereby simplifying editing operations.
- Adding/deleting/replacing processes, and changing/editing cutting cycles can be done easily using soft keys.



*T-PROGRAM GUIDE is based on the FANUC manual guide.

F Loader System

Featuring Functions Unique to TAKAMAZ!

- Realizes High Productivity through Increased Loader Speed and Shorter Machine Stoppage Times

Productivity improvement

- Traverse axis: **MAX.160m/min**
- Vertical axis: **MAX.160m/min**

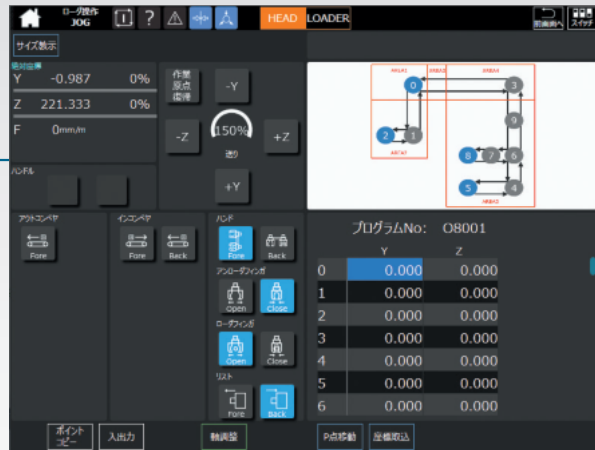

- Shorter Setup Times by Functions Unique to TAKAMAZ

Ease-of-setup improvement

- Loader system operation can be checked safely using handle operation.
- Two types of teaching methods are available to suit various situations.

Loader Size Display Function



When setting up after changing the loader workpiece, teaching can be completed by simply setting the workpiece size.

Y-Axis Automatic Adjustment Function

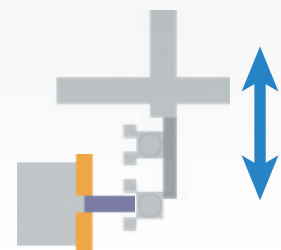

When teaching the loader, the Y-axis position can be automatically adjusted just by repeatedly opening and closing the fingers.

- Loader Speed Optimization Function for Energy Savings and Longer Service Life

Energy saving functions

- By automatically optimizing the speed of the loader, loader energy savings and a longer loader service life are achieved.

- In Addition to a Touch Panel Giving Exceptional Loader Operability, a Servo System Made by FANUC Is Adopted.

TAKAMAZ OS

TAKAMAZ Technology Aids Productivity

- Functions for Better Working Efficiency in Addition to Conventional NC Screens
- Work Simplified by Automation of Operations and Network Function

Better Working Efficiency

Operator working efficiency improved, reducing production stoppage time



Keeping Track of Production Progress

Production count and tool usage count can be determined at a glance.

Display of Start Conditions

Operations to prepare for starting can be performed quickly.

Machine Stoppage Warning

Advance warning of the next machine stoppage is displayed based on the workpiece count, etc.

Camera Image Display (Option)

Makes it possible to check areas that are difficult to see, like the rear section of the machine.

Quality Control

Storing of traceability information per workpiece to assist quality control

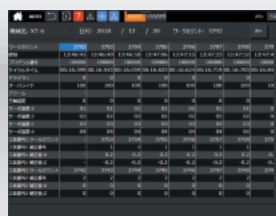

The status of the machine during machining and can be checked and the information can be used for quality control and preventive maintenance.

Examples of Traceability Data

Times, motor temperatures, cycle times, program numbers, tool wear offsets, etc.

IT & IoT

Programs can easily be input and output between machines via the network.

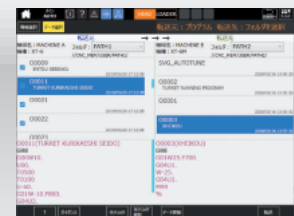

Simple On-Screen Input/Output

No need to move between machines

No need for USB flash drives

No need for an external computer



F.T. Japan Inc.

F.T. Japan imports machines manufactured by FEELER, ECOCA, and LEADWELL from our affiliate FFG Group (Taiwan), the world's third-largest general machine tool manufacturer, and sells them.

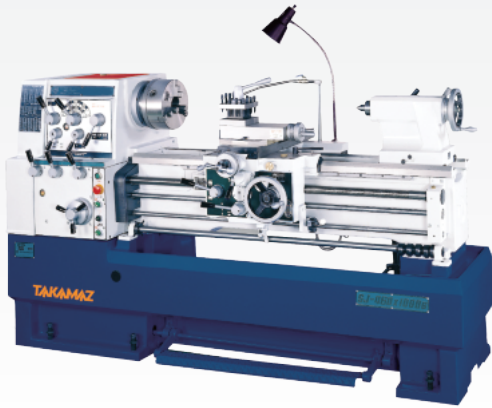

■ General-Purpose Lathe SJ460 × 1000G

This is a general-purpose lathe manufactured by ECOCA. It has excellent cost performance and is available in a wide range of sizes. The apron handle position can be selected from either the left or right sides. Slides are hardened/polished. Equipped with an auto-feed stopper ring, machining that meets your needs can be accomplished.

Equipment sold by the TAKAMAZ Group will be fully supported by the TAKAMAZ service network.

Head Office and Plant

■ TAKAMATSU MACHINERY CO., LTD.

· HEAD OFFICE

1-8 ASAHIGAOKA HAKUSAN-CITY ISHIKAWA JAPAN. 924-8558
TEL +81-(0)76-207-6155 FAX +81-(0)76-274-1418

· ASAHI PLANT

4-13 ASAHIGAOKA HAKUSAN-CITY ISHIKAWA JAPAN. 924-0004
TEL +81-(0)76-274-0123 FAX +81-(0)76-274-8530

Overseas Bases

■ TAKAMATSU MACHINERY U.S.A., INC.

· CHICAGO HEAD OFFICE

1280 LANDMEIER ROAD ELK GROVE VILLAGE, IL 60007 USA
TEL +1-(0)847-981-8577 FAX +1-(0)847-981-8599

■ TAKAMAZ MACHINERY EUROPE GmbH

IM HÜLSFELD 19, 40721 HILDEN, GERMANY
TEL +49-(0)2103-789-4882 FAX +49-(0)2103-789-4883

■ TAKAMAZ MACHINERY (HANGZHOU) CO., LTD.

· HANGZHOU HEAD OFFICE

NO.6800, JIANGDONG 3RD ROAD, JIANGDONG INDUSTRIAL PARK,
XIAOSHAN, HANGZHOU, ZHEJIANG, CHINA
TEL +86-(0)571-8287-9709 FAX +86-(0)571-8215-3732

■ TAKAMATSU MACHINERY (THAILAND) CO., LTD.

· BANGKOK HEAD OFFICE

888/59 MOO 9, TAMBOL BANGPLA, AMPHUR BANGPLEE,
SAMUTPRAKARN PROVINCE, THAILAND
TEL +66-(0)2-136-7831 FAX +66-(0)2-136-7834

■ PT. TAKAMAZ INDONESIA

JL. FESTIVAL BOULEVARD BLOK AA 11 NO.30,31 GRAND WISATA TAMBUN, BEKASI 17510
TEL +62-(0)21-8261-6431 FAX +62-(0)21-8261-6430

■ TAKAMAZ MACHINERY MEXICO, S.A.DE C.V.

AVENIDA DE LOS INDUSTRIALES 522, LOCAL 4, INDUSTRIAL JULIAN DE OBREGON,
37290 LEON, GUANAJUATO MEXICO
TEL +52-477-784-0468

■ TAKAMATSU MACHINERY VIETNAM CO., LTD

NO.76 M HOANG QUOC VIET, PHU MY WARD, DISTRICT 7, HO CHI MINH CITY, VIETNAM
TEL +84-(0)28-3620-5671 FAX +84-(0)28-3620-5673

Affiliated Companies

■ HANGZHOU FEELER TAKAMATSU MACHINERY CO., LTD.

NO.6800, JIANGDONG 3RD ROAD, JIANGDONG INDUSTRIAL PARK,
XIAOSHAN, HANGZHOU, ZHEJIANG, CHINA
TEL +86-(0)571-8215-3760 FAX +86-(0)571-8286-5311



<https://www.takamaz.co.jp>



Scan this QR Code
for more details. ▶

